

CARACTÉRISTIQUES

- Machine robuste.
- Tapis en PVC.
- Commande manuelle :
SM-520A / SM-520S: par boutons.
SM-520F: par levier.
- Vitesse 50 cm/sec.
- Tables relevables.

FEATURES

- Robust machine.
- PVC conveyor belts.
- Manual operation:
SM-520A / SM-520S: by push buttons.
SM-520F: by handle.
- Speed 50 cm/sec.
- Tables can be raised after operation.

EIGENSCHAPPEN

- Robuste machine.
- PVC transportbanden.
- Handbediening:
SM-520A / SM-520S: met drukknop.
SM-520F: met hendel.
- Snelheid 50 cm/sec.
- Opklapbare tafels.



Tables relevables.
Tables can be raised after operation.
Opklapbare tafels.

Tapis en PVC.
PVC conveyor belts.
PVC transportbanden.



Équipé avec roulettes
pourvues de frein, facile à déplacer.

Mounted on castors with locking
system, easily movable.

Uitgerust met zwenkwielen
met rem, makkelijk te verplaatsen.

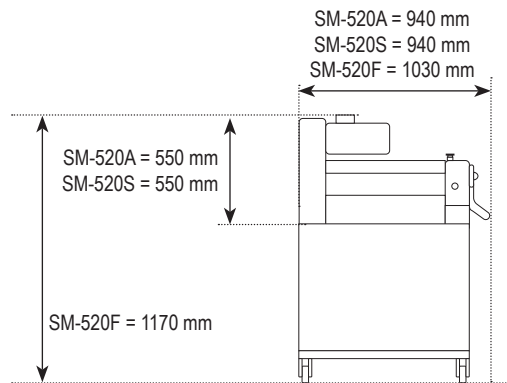
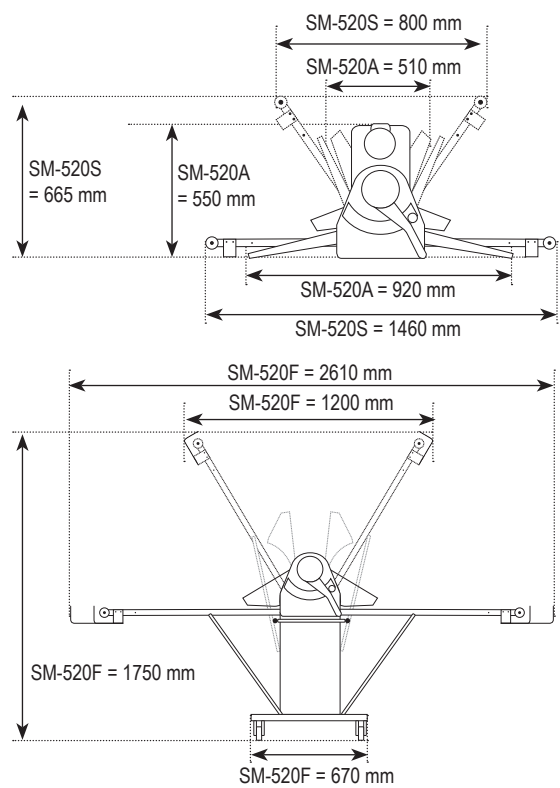
VUE LATÉRALE | SIDE VIEW | ZIJAANZICHT

VUE DE FACE | FRONT VIEW | VOORAANZICHT

SM-520A
SM-520S
SM-520F

MODEL	SM-520A	SM-520S	SM-520F
MODÈLE SUR SOCLE MODEL WITH SUPPORT SOKKELMODEL	✗	✗	✓
PUISSANCE MOTEUR MOTOR POWER MOTORVERMOGEN	0,37 kW	0,37 kW	0,55 kW
POIDS NET MACHINE NET WEIGHT MACHINE NETTOGEWICHT MACHINE	80 kg	100 kg	168 kg
LARGEUR DU LAMINAGE WORKING WIDTH UITROLBREEDETE	520 mm	520 mm	520 mm
LONGUEUR DU TAPIS CONVEYOR BELT LENGTH LENGTE TRANSPORTBAND	2 x 420 mm	2 x 670 mm	2 x 980 mm
ÉCART ENTRE LES ROULEAUX SPACE BETWEEN ROLLERS RUIMTE TUSSEN DE ROLLEN	1 - 30 mm	1 - 30 mm	1 - 30 mm
VOLTAGE VOLTAGE SPANNING	230/400V 3Ph 50Hz	230/400V 3Ph 50Hz 230V 1Ph 50Hz	230/400V 3Ph 50Hz